

TANKO® CR

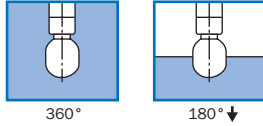

The TANKO® CR has been developed for maximum chemical resistance and highest hygienic requirements. It provides impressive corrosion resistance and strong cleaning.

The TANKO® CR series of spatula cleaners rotate in a slow and defined manner on a maintenance-free hydrodynamic plain bearing. This constantly flushed bearing allows operation in the widest variety of installation angles, resulting in a sturdy device with a long service life. The constant speed under different operating conditions and focused fan jets ensure high cleaning effectiveness in conjunction with fast wetting. The TANKO® CR is also very well suited for SIP sterilization of the vessel with steam.

The material used is a modified 2nd generation PTFE that provides a smoother, more hygienic surface than conventional PTFE with improved mechanical properties at the same level of chemical resistance and freedom from adhesion.

All consumption specifications are for orientation only.
The dimensions listed are in mm and are nominal dimensions.

Technical Parameters

Spray angle:	360°, 180° downwards
Materials:	Modified PTFE
Connections:	1/4" BSP female thread 1/2" BSP female thread 1" BSP female thread
Operating pressure:	Cleaning medium: 1,5 - 5 bar / 22 - 73 psi *
Working temperature:	Cleaning medium: +5 °C to +95 °C / +41 °F to +203 °F
Ambient temperature:	Inside the container: +5 °C to +150 °C / +41 ° to +302 °F
Volume flow rate:	1.5 - 12 m³/h / 25.5 - 200 l/min / 6.7 - 52.8 gpm (US) *
Range:	Cleaning radius: 0.5 - 3.2 m / 1.6 - 12 ft Wetting radius: 1.3 - 4.3 m / 4.3 - 14 ft *
Min. installation opening:	CR30 Ø 32 mm / 1.26 in CR40 Ø 47 mm / 1.85 in CR50 Ø 74 mm / 2.91 in

*Depending on model and cleaning medium

Structure

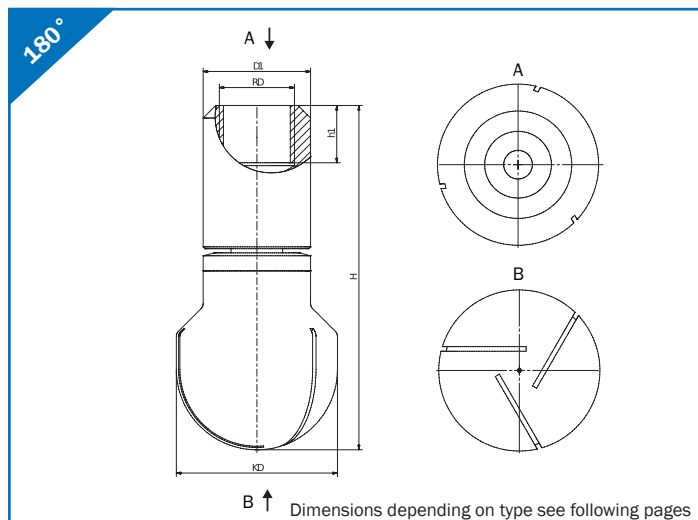
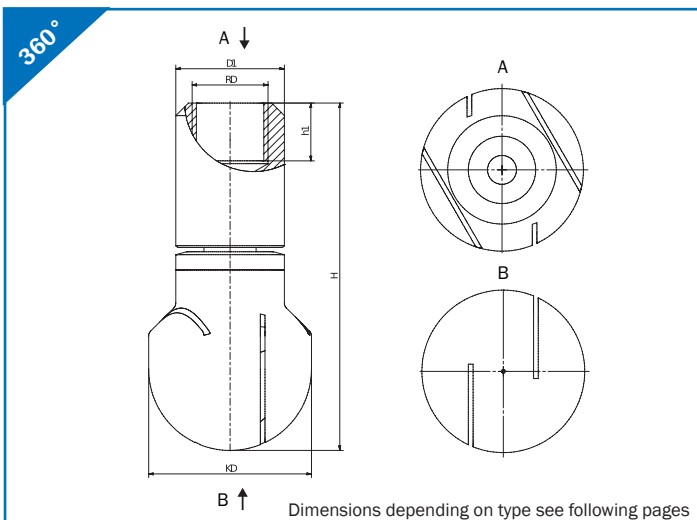

Consumption and Throw Length Data

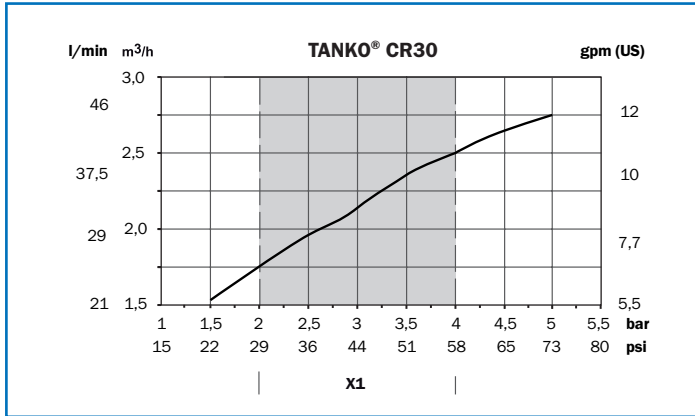

X1 – recommended operating pressure

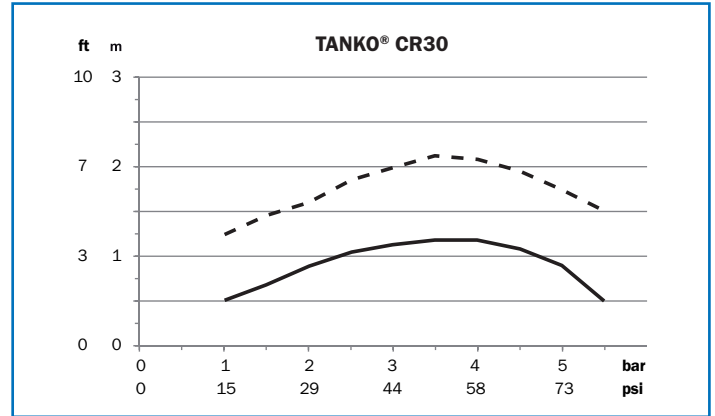

--- Wetting radius — Cleaning radius

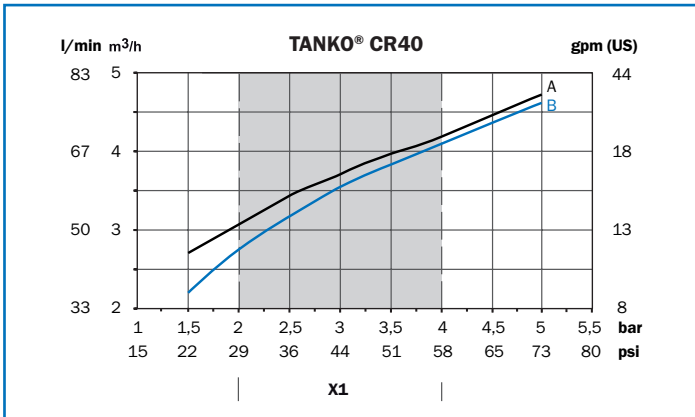

X1 – recommended operating pressure
A - 360° / **B** - 180° downwards

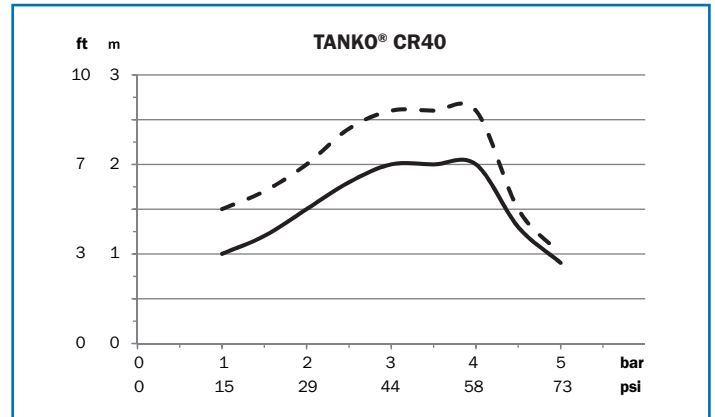

--- Wetting radius — Cleaning radius

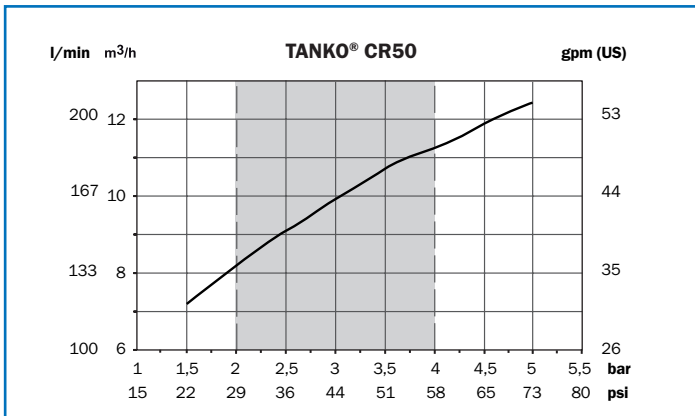

X1 – recommended operating pressure

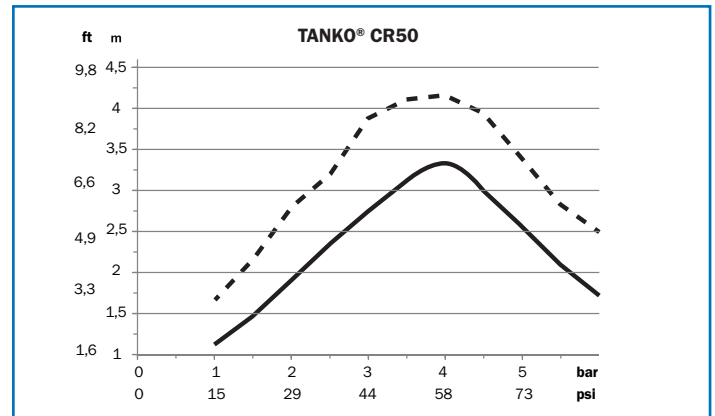

--- Wetting radius — Cleaning radius

Services

Material Certificates

Description	Net price/EUR
FDA / EU 10/2011 / USP class VI TANKO® CR	30,00

TANKO® CR

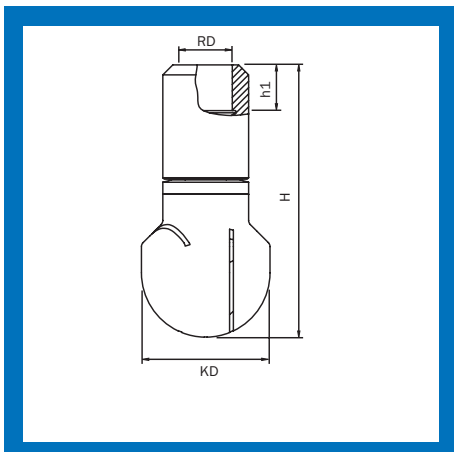

TANKO® CR, 360°

Type	RD	D1	KD	H	h1	Weight [kg]
CR30	1/4" BSP	21	32	67	11	0,05
CR40	1/2" BSP	30	45	96,2	16	0,14
CR50	1" BSP	50	72	138,2	22,5	0,52

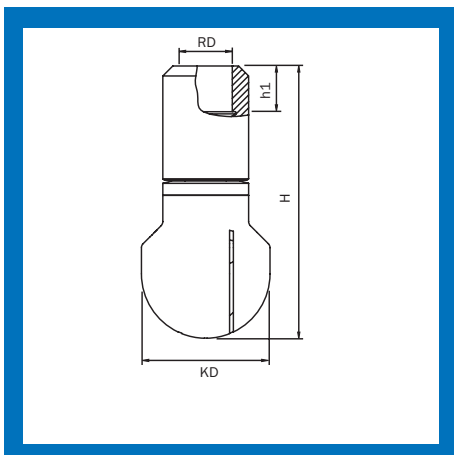

TANKO® CR, 180° downwards

Type	RD	D1	KD	H	h1	Weight [kg]
CR30	1/4" BSP	21	32	67	11	0,05
CR40	1/2" BSP	30	45	96,2	16	0,14
CR50	1" BSP	50	72	138,2	22,5	0,52

TANKO® CR

TANKO® CR, 360°

DN	Price/EUR	Article no.
1/4"	220,00	66K 03 5000 13K0
1/2"	250,00	66K 04 5200 13K0
1"	430,00	66K 05 5400 13K0

TANKO® CR, 180° downwards

DN	Price/EUR	Article no.
1/4"	220,00	66K 03 5000 23K0
1/2"	250,00	66K 04 5200 23K0
1"	430,00	66K 05 5400 23K0