

TANKO® MX150

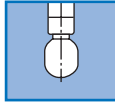

360°

The design-protected TANKO® MX150 is a media-powered jet cleaner with constant rotation.

The device is used in a wide range of industrial applications where vessels and tanks need to be power-cleaned. Due to the compact design of the unit, the TANKO® MX150-G14 (4-nozzle) can be introduced into the tank through openings with a minimum diameter of 150 mm and the TANKO® MX150-G12 (2-nozzle) through openings with a minimum diameter of 115 mm.

The 360° spray pattern cleaning is based on 4 or 2 nozzles. The device has plain bearings and epicyclic gearing. It has been designed to produce the best cleaning results. It is self-cleaning, high-impact and still has impressively low consumption figures.

All consumption specifications are for orientation only.
The dimensions listed are in mm and are nominal dimensions.

Technical Parameters

Spray angle:	360° orbital
Materials:	1.4404 (316L), 1.4401 (316), C-PTFE, PEEK+PTFE (FDA-compliant)
Connections:	1 ½" BSP or NPT female thread
Operating pressure:	Cleaning medium: 3 - 8 bar/43.5 - 116 psi
Working temperature:	Cleaning medium: max. 95°C / 203°F
Volume flow rate:	MX150-G14: 10.5 - 20.5 m ³ /h / 175 - 342 l/min / 46 - 90 gpm (US)* MX150-G12: 5.8 - 11.6 m ³ /h / 97 - 193 l/min / 26 - 51 gpm (US)*
Rotation speed (RPM):	approx. 5 - 14 rpm*
Range:	Cleaning radius: MX150-G14: max. 7.5 m / 24.61 ft, MX150-G12: max. 7.8 m / 25.59 ft Wetting radius: MX150-G14: max. 10.5 m / 34.45 ft, MX150-G12: max. 9.8 m / 32.15 ft
Weight:	MX150-G14: 3.6 kg, MX150-G12: 3.5 kg
Installation position:	vertically suspended (other positions possible with reduced service life of the wearing parts)
Min. installation opening:	MX150-G14: Ø 150 mm / 6 in, MX150-G12: Ø 115 mm / 4½ in
Bearing:	plain bearing

*Depending on model and cleaning medium

Dimensions

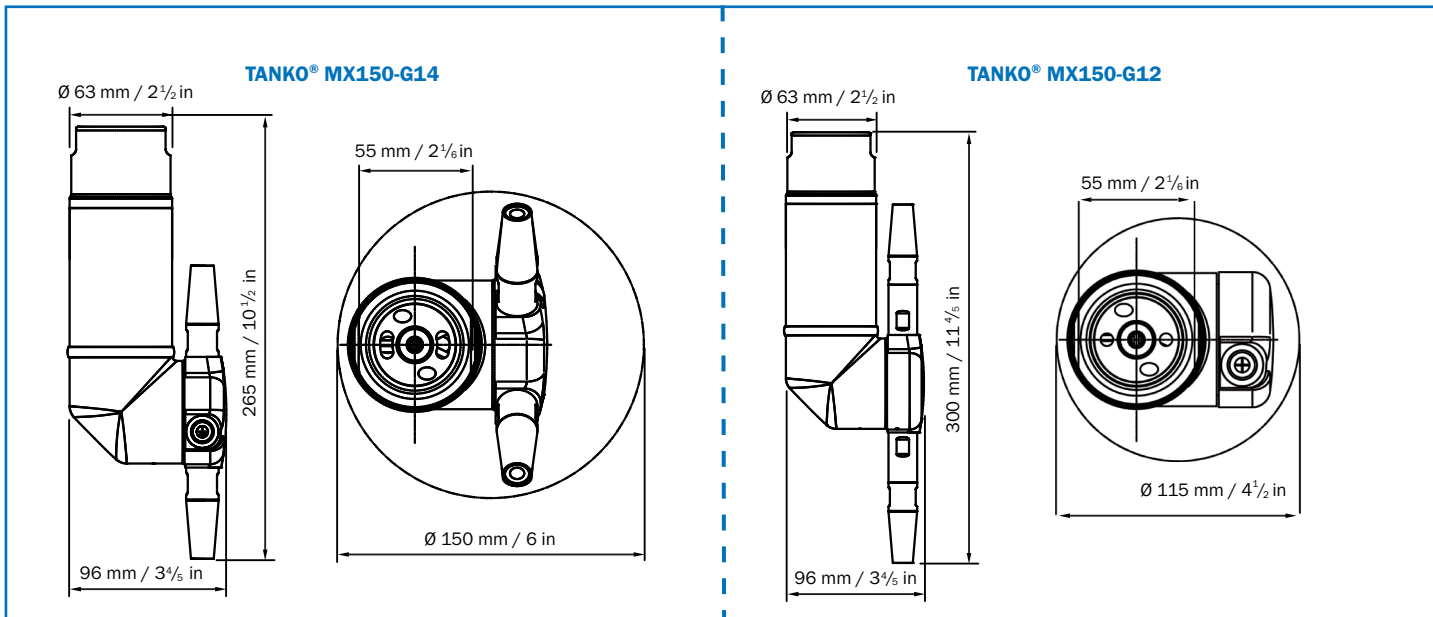

TANKO® MX150

Consumption Data and Throw Length Data

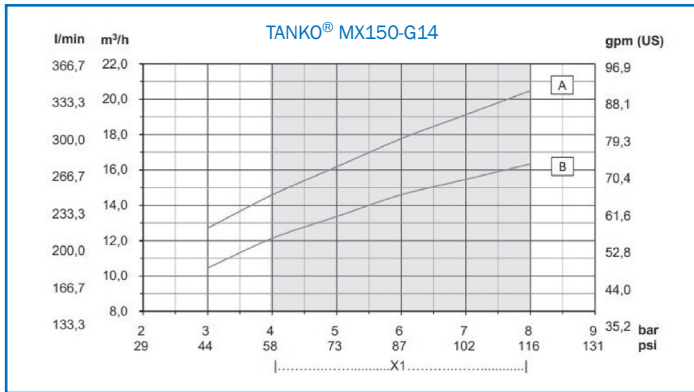

A - 4 x Ø 8 mm B - 4 x Ø 7 mm

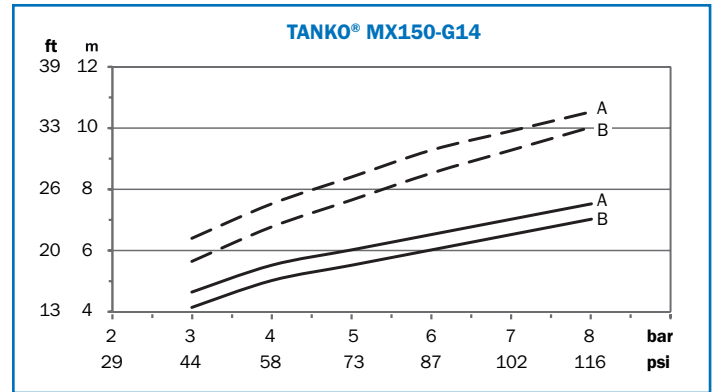

A - 4 x Ø 8 mm B - 4 x Ø 7 mm

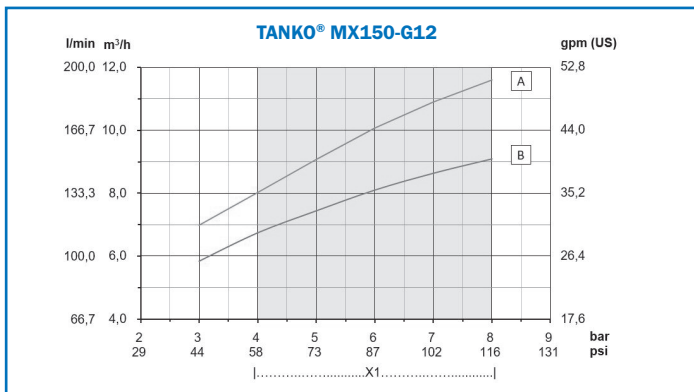

A - 2 x Ø 8 mm B - 2 x Ø 7 mm

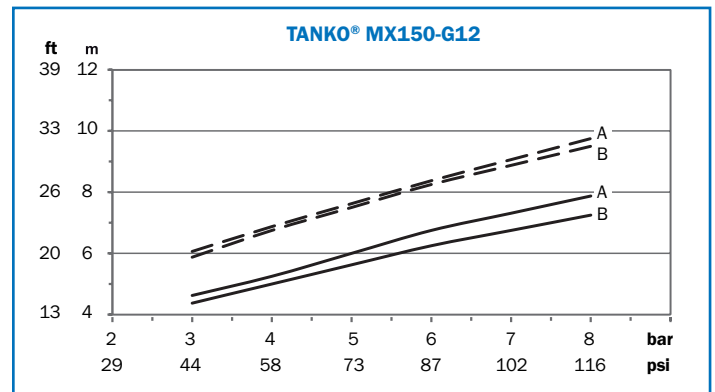

A - 2 x Ø 8 mm B - 2 x Ø 7 mm

X1 - recommended operating pressure

— Wetting radius — Cleaning radius

Ordering Information

TANKO® MX150				
Article no.	Connection	Description	Nozzles	Price/EUR
66M B40 3NG TB20	1 ½" BSP (female thread)	TANKO-MX150-G14	4 x Ø 7 mm	2.300,00
66M B40 3NG UB20	1 ½" BSP (female thread)	TANKO-MX150-G14	4 x Ø 8 mm	2.300,00
66M B40 4NG TB20	1 ½" NPT (female thread)	TANKO-MX150-G14	4 x Ø 7 mm	2.300,00
66M B40 4NG UB20	1 ½" NPT (female thread)	TANKO-MX150-G14	4 x Ø 8 mm	2.300,00
66M B20 3NG TB20	1 ½" BSP (female thread)	TANKO-MX150-G12	2 x Ø 7 mm	2.300,00
66M B20 3NG UB20	1 ½" BSP (female thread)	TANKO-MX150-G12	2 x Ø 8 mm	2.300,00
66M B20 4NG TB20	1 ½" NPT (female thread)	TANKO-MX150-G12	2 x Ø 7 mm	2.300,00
66M B20 4NG UB20	1 ½" NPT (female thread)	TANKO-MX150-G12	2 x Ø 8 mm	2.300,00

Spare Parts and Services

Spare Parts		
Article no.	Description	Price/EUR
66M A00 OVG 0000	Wearing Parts Packages for TANKO® MX	242,00

Material Certificates	
Description	Net price/EUR
WAZ 3.1 - EN10204 - TANKO® MX	125,00