

## TANKO® R64T

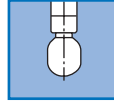
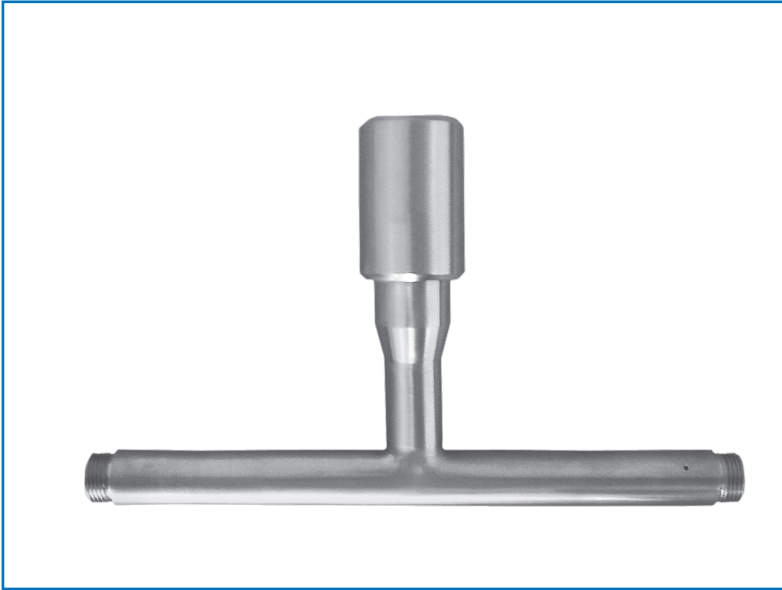

360°

Der TANKO® R64T rotates on a vertical axis. In conjunction with two TANKO® S30 or TANKO® RB30 devices, even hard-to-reach areas can be optimally cleaned.

All consumption specifications are for orientation only.  
The dimensions listed are in mm and are nominal dimensions.

### Technical Parameters

<b>Spray angle:</b>	360°
<b>Materials:</b>	In contact with medium: 1.4435 (316L), ball bearing 1.4404 (316L)
<b>Connections:</b>	Medium connection: 3/4" BSP female thread Process connection: 3/8" BSP male thread for TANKO® S30 or TANKO® RB30
<b>Operating pressure:</b>	1.5 - 7 bar / 21.8 - 101.5 psi (Depending on the installed cleaning device!)
<b>Working temperature:</b>	Cleaning medium: max. 230 °C / 446 °F (Does not apply to ATEX versions!)
<b>Ambient temperature:</b>	Inside the vessel: max. 250 °C / 482 °F (Does not apply to ATEX versions!)
<b>Volume flow rate:</b>	2 x TANKO® S30 360° BSP: 4.9 - 7.2 m³/h / 81.7 - 120 l/min / 21.6 - 31.7 gpm (US) *
<b>Range:</b>	Cleaning radius and wetting radius depend on the version
<b>Installation position:</b>	vertically suspended, other positions on request
<b>Bearings:</b>	double spray ball bearings
<b>Surface:</b>	hand polished

\*Depending on model and cleaning medium

### Information as per ATEX (excerpt)

The cleaning devices satisfy the explosion protection requirements of Directive 2014/34/EU.

**Current information on the type approval of the cleaning devices:** TANKO® R64T

(G = Gas, D = Dust, X at the end of the identification number = Special conditions, see operating instructions)

⊕ II 1 G Ex h IIB T6 Ga

II 1 D Ex h IIIC T60 °C Da

TPS 20 ATEX 055073 009 X

The technical data of the ATEX units can differ from the standard units and this data is provided in the respective operating and installation instructions.

Article no.: please take the respective article number and substitute the 4th digit from the front with an "X". E.g.: 66TX\_\_\_\_\_

Surcharge on standard products from the TANKO® R64T series: 265.00 EUR.

# TANKO® R64T Connection BSP 3/3 Standard

## Configuration examples

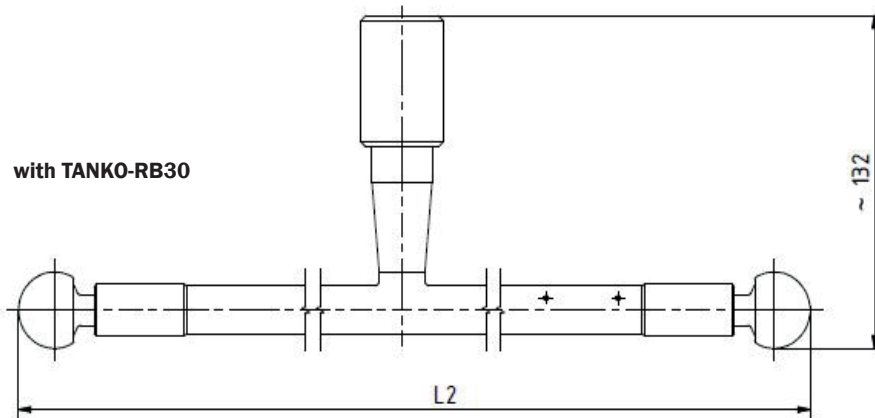
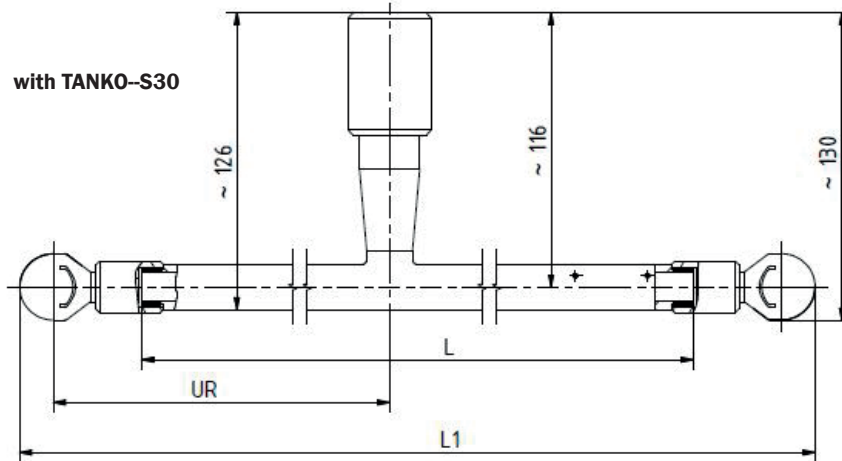

## Consumption TANKO® R64T with 2 x TANKO® S30 360°

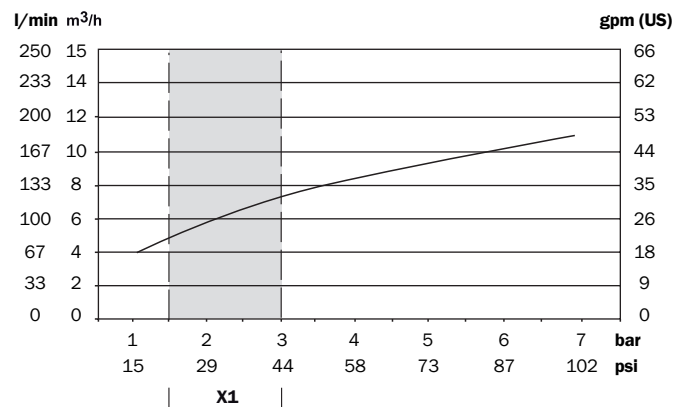

**X1** – recommended operating pressure

## Ordering Information

TANKO® R64T							
Article no.	x [mm]	L [mm]	L1 [mm]	L2 [mm]	Weight without CD [g]	Price/EUR	
66T0 513 4131 3131 *	111	148	250	270	352	710.00	
66T0 513 4131 3132 *	201	328	430	450	473	710.00	
66T0 513 4131 3133 *	291	508	610	630	590	710.00	
66T0 513 4131 3134 *	366	658	760	780	688	710.00	
66T0 513 4131 3130 *	Length according to customer specifications					*	

\* TANKO® S30 not included in the scope of delivery

# TANKO® R64T Clipon Connector for A29 Series

## Configuration examples

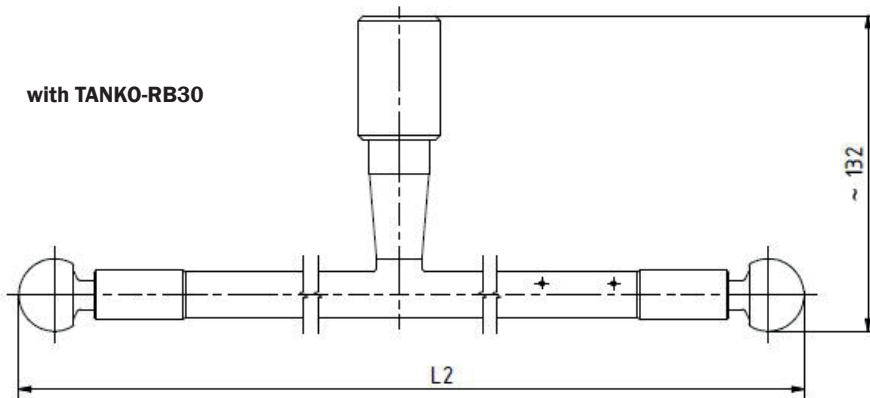
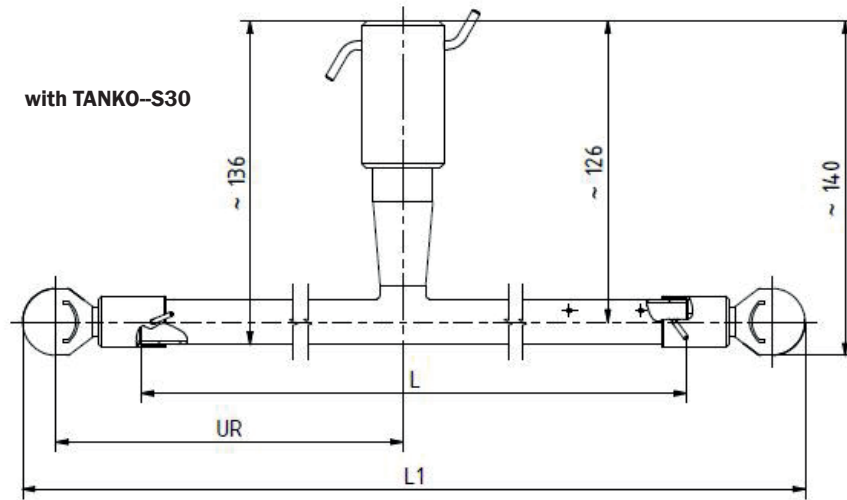

## Consumption data TANKO® R64T with C TANKO® S30

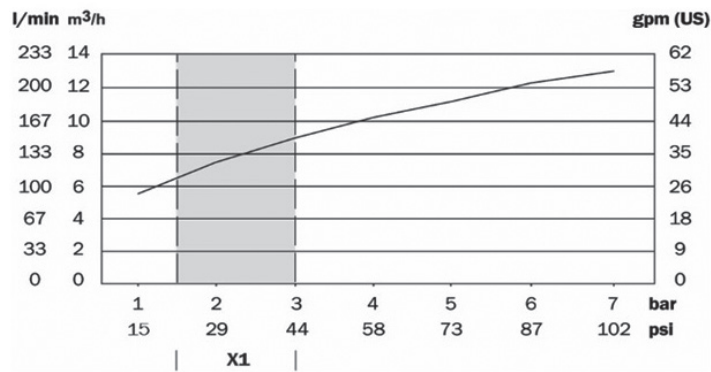

X1 – recommended operating pressure

## Ordering Information

### TANKO® R64T

Article no.	x [mm]	L [mm]	L1 [mm]	L2 [mm]	Weight without CD [g]	Price/EUR
66T0 512 4134 3131 *	111	148	250	278	365	710,00
66T0 512 4134 3132 *	201	328	430	458	484	710,00
66T0 512 4134 3133 *	291	508	610	638	604	710,00
66T0 512 4134 3134 *	366	658	760	788	703	710,00

\* TANKO® S30 not included in the scope of delivery