

TANKO® RTF

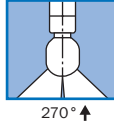
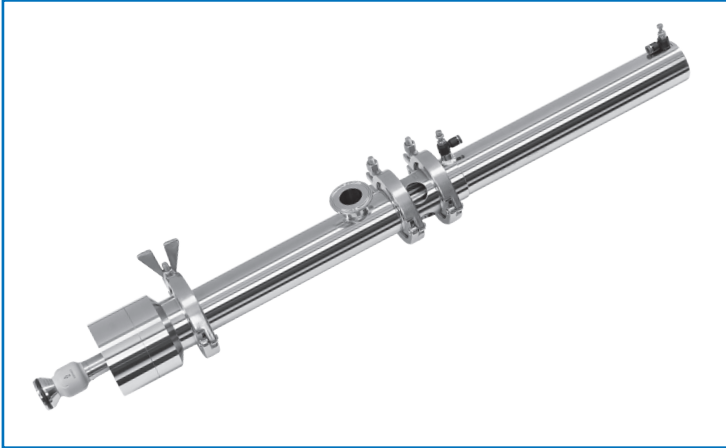

The TANKO® RTF is a retractor. A modified version of the TANKO® SF hydrodynamic spray head is used here.

The TANKO® RTF is available with stroke lengths of 100, 150, 250 and 500 mm and the type "WF" head. Due to the special form, the TANKO® RTF is approx. 50 mm longer than the TANKO® RT.

All consumption specifications are for orientation only.
The dimensions listed are in mm and are nominal dimensions.

Technical Parameters

Spray angle:	270° upwards
Materials:	In contact with medium: 1.4401 (316), 1.4430, 1.4435 TECA-PEEK, PTFE modified, EPDM, optional FKM Not in contact with medium: 1.4301 (304), PU, Al
Connections:	Medium connection: Clamp acc. DIN 32676 (series A) DN25, optional: MA adapter DN25 / 1" + seal ring + heavy duty clamp DIN 32676 for DN25; Process connection: Weldon connections, combination adapter C3
Operating pressure:	Cleaning medium: 1 - 3 bar / 14.5 - 43.5 psi * Pneumatic system: min. 5 bar / 72.5 psi , max. 8 bar / 116 psi
Working temperature:	Cleaning medium: max. 95°C / 203°F
Ambient temperature	inside the vessel. 140°C / 284°F, outside the vessel: max. 60°C / 140°F
Sterilization temperature:	121°C / 250°F for a short time (special conditions must be observed, see operating instructions)
Volume flow rate:	3.3 - 5.5 m³/h / 55 - 91.7 l/min / 14.5 - 24.2 gpm (US) *
Range:	Cleaning radius: max. 1.5 m / 4.9 ft Wetting radius: max. 2 m / 6.6 ft

*Depending on model and cleaning medium

Spray Head Variants

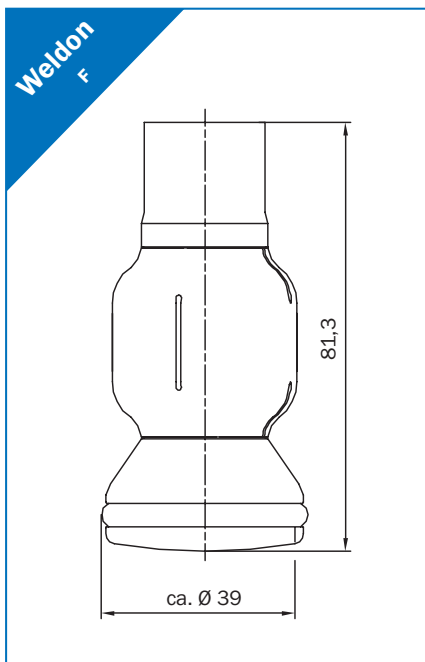

R = Cleaning holes as per customer specifications
E = Drain perforation

Process Connections

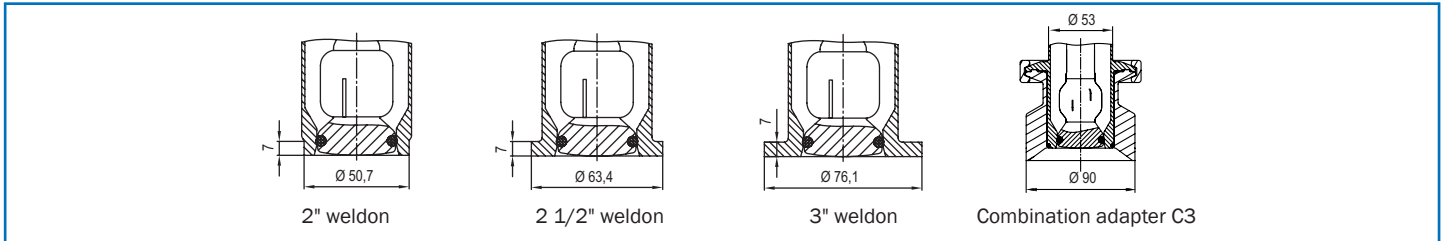

Installation Advice regarding Self-draining

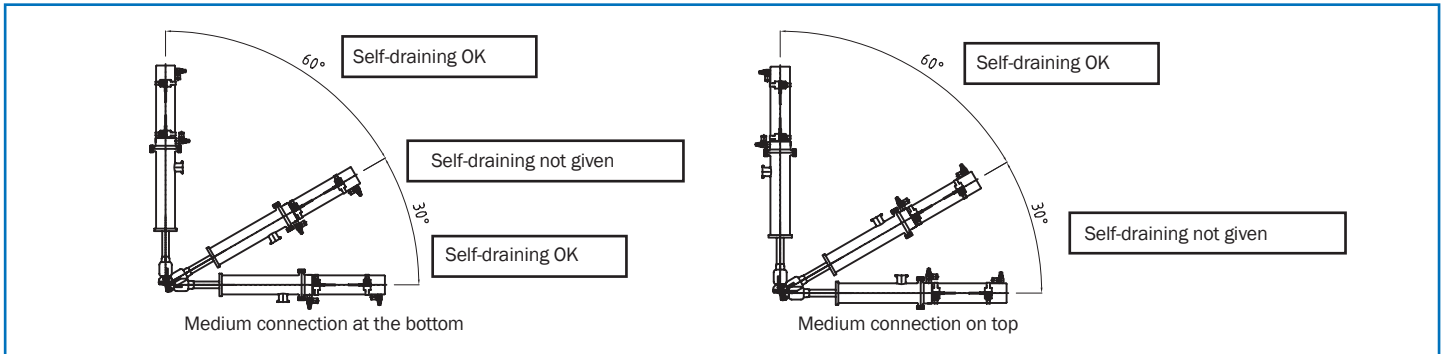

Consumption Data and Throw Length Data

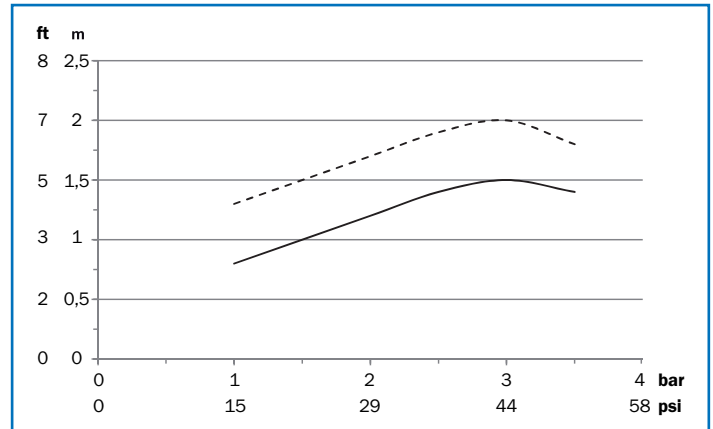
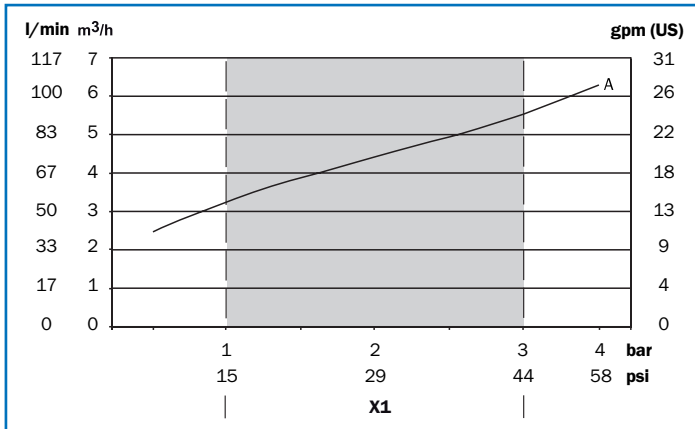

A – 270° weldon

— Wetting radius - - - Cleaning radius

X1 – recommended operating pressure

Spare Parts

Spare Parts and Wearing Parts Packages

Article no.	Description	Price/EUR
66RA1001VA00000	Wearing parts package EPDM	310.00

Replacement O-ring* for Sealing the Retractor Combination Vessel Connector in the TANKO® RTF

Article no.	Material	Designation	Net price/EUR
10605222BE70S1	EPDM	ORi d 37.69x3.53 DIN ISO 3601-1	*

*) Applies only to O-rings contacting the product